



August 2023 NRL22 Official Course of Fire

Announcement: The 2023 NRL22 National Championship is a wrap! Thank you, Chris Simmons and Jon Cole for hosting. We had 230+ competitors come battle it out as to who is going to be crowned the 2023 NRL22 & NRL22X National Champions. We would like to congratulate Zane Hermann in being crowned the NRL22 Champion and Ben Blevins being crowned the NRL22X Series Champion for the 2023 season.

Additionally, congrats to Top Base – Matt Steele , Top Young Gun – Dakota Wright, Top Lady – Camdyn Powers, Top Air Rifle – Matthew Dubber, and Top Old Guns – Tony Maupin.

We look forward seeing you all at a match and at the 2024 NRL22 National Championship next year in Frederic, WI hosted by Ruth Soucie & Justin Carbone.

Please take a look at this video on how to use a tripod as rear support for one of the stages this month. [Tripod Video](#)

PractiScore Template: Here is the link for the PractiScore template for this month's COF. This template has all the stages already built for you if you don't want to create them yourself. All you need to do is follow the instructions to the letter otherwise you risk your match results being overwritten. [PractiScore Template](#)

DFAT Range Card: The DST Precision DFAT allows you to use the rifle and optic to dryfire practice in a very small area such as your garage, living room, or even bedroom. With this adapter most scopes focus in the 11-15 feet range. You can find this month's COF range card here. [DFAT Range Practice Range Card](#)

COF Designer: Thank you to Darron DeBoer from Free State Precision Plinkers out of Ottawa, KS. Darron did a great job in designing this COF and the ability to use multiple props within a stage that we have rarely done. Thank you Darron for volunteering to write a COF and what you do for this amazing sport.

If you have questions about the COF please email Dominic at Dom@NRL22.org

Range requirements: This month's COF will require a Ladder, Tripod, NRL22 Pyramid, 3x Cinder Blocks, Rooftop, 2x Tires, Chair, a stopwatch that can time down to a tenth of a second, and the NRL22 standard target package. Left over targets: 2x 1", 1x 1.5", 1x 2", 2x 2.5", 1x 3", 4", 5", 6"

Scoring submissions: In accordance with the 2024 NRL22 rules, Match Directors are required to submit scores within 7 days of their match concluding. You can submit your NRL22 (5 stages only) scores through the NRL22 website using the Practiscore URL. If you don't have that ability then download the NRL22 Scores sheet from the downloads section on NRL22.org/downloads, fill out the results, and submit scores through the NRL22.org, followed by payment for the match admin fee. Keep in mind that only NRL22 members are eligible for prizes and while we have a 7-day grace period for membership, if the prizes are already distributed, it is the competitor's loss.

Live Stream: The live show for prizes will happen on **September 13th, 2023**. If you have questions, ask them during the live show and we will answer them for you.

Terms of Use

The use of this course of fire is restricted to personal/individual use; however, the use of this course of fire in a match setting must be operated within the NRL22 rules and is restricted to current NRL22 clubs. The monthly course of fire is a proprietary product of the NRL22. Furthermore, the scores of every competitor at that match must be submitted to the NRL22 regardless of the competitor's membership status. Every competitor is given a 7-day grace period to become a member and claim their score.

August 2023 NRL22 Official Course of Fire

Here is the running list of approved out-of-production rifles that will remain in base division. These rifles must be in their original factory configuration to be eligible for base division. The only modifications to those rifles are the ones listed in the NRL22 Rules Section 5. B. The burden of providing solid evidence for inclusion into base division rests squarely on the shooter, and the MD makes the final call on which division the shooter's rifle gets classified in. If there are out-of-production rifles that are not on this list, please email Dom at Dom@NRL22.org with the manufacturer, model number, and MSRP (not MAP) with a website where it was to be considered for inclusion.

- CZ 452 (all models)
- CZ 455 (all models)
- Savage (all models, except Savage Anschutz)
- Ruger (all models)
- Marlin/Glenfield
 - Levermatic
 - Model(s) 780, 880, 980
 - XT-22
- Mossberg (all models)
- Winchester
 - Model 69 & variants
 - Model 131 & 141 (including SR variants)
- Cooley
 - 64 (predecessor to Savage 64)

- Example #1: The CZ 452 American had an MSRP of \$409.00 in 2007. Inflation adjustment puts that MSRP at \$614.52 in 2023. This is clearly in line with many other "base division" rifles including several versions of the CZ 457.
- Example #2: The CZ 455 Varmint Precision Trainer had an MSRP of \$967 in 2018. Inflation adjustment puts that MSRP at \$1,186.49 in 2023. Unless the competitor is electing to shoot with iron sights, it would be practically impossible for this model to stay under the applicable \$\$\$ threshold.
- Example #3: The Winchester Model 52 Sporter had an MSRP of just \$88.50 in 1934. However, 90 years of compound inflation really adds up. Inflation adjustment puts that MSRP at \$2,039.03 in 2023. The Model 52 will be a ton of fun to shoot, ...in Open division.

Inflation/compound interest calculator can be found at [here](#)

Terms of Use

The use of this course of fire is restricted to personal/individual use; however, the use of this course of fire in a match setting must be operated within the NRL22 rules and is restricted to current NRL22 clubs. The monthly course of fire is a proprietary product of the NRL22. Furthermore, the scores of every competitor at that match must be submitted to the NRL22 regardless of the competitor's membership status. Every competitor is given a 7-day grace period to become a member and claim their score.

Science Fair Bridge Building

Time: 120 Sec

Round Count: 12

Option 1 – 55 yds: 1.5” on a single hanger
95 yds: 2.5” on a single hanger

Ranges and Targets:

Option 2 – Same targets and distance.

Stressor: Engage near target then far target with 2 shots each. Alternating between the 3rd & 4th step after every 2 shots.

Restrictions: 1 Bag Only. May use arca plate/barricade stops.

Points: 10 points per impact, 120 points possible

Start Position: Standing 10’ behind the ladder, rifle grounded next to the ladder w/ mag in, action open, bag attached or in hand, Tripod in hand (if used). ***Tripod use is optional and is fully deployed.***

Adaptive Recommendation: Use the highest 2 steps you can reach. Same target engagement.

Description: On the start signal, build a position on the 3rd step of the ladder and engage targets with 3 shots near and then 3 shots far.

You will then move up to the 4th step and engage targets with 3 shots near and then 3 shots far.

If you can't reach steps 3 & 4, you can use steps 2 & 3.

*More experienced competitors are encouraged to use the tripod during the stage to demonstrate how tripods can be used as rear support.

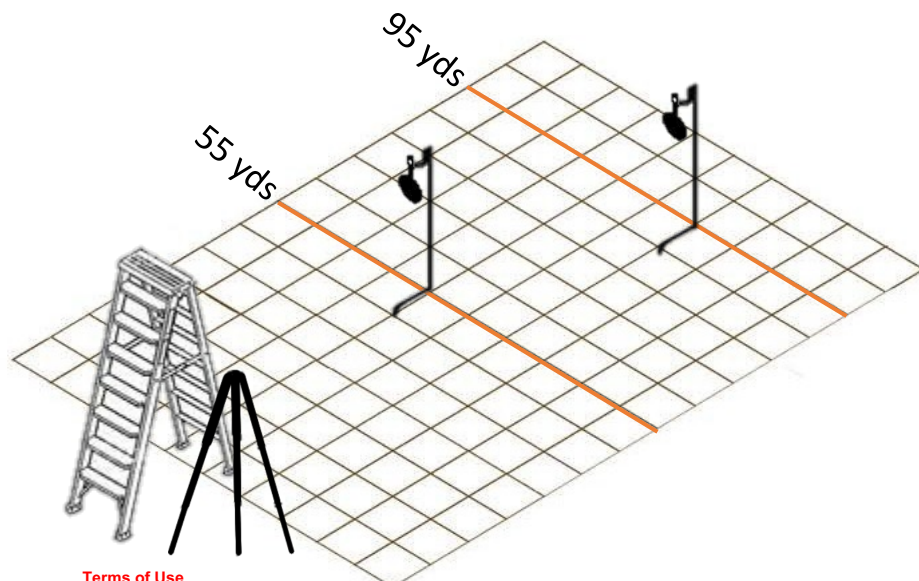

Terms of Use

Fractions Are Hard

Time: 120 Sec

Round Count: 10

Ranges and Targets:

Option 1 – 40 yds: $\frac{3}{4}$ ", $\frac{1}{2}$ ", $\frac{1}{4}$ " on a KYL rack
85 yds: 1.5" on a single hanger

Option 2 – 60 yds: 1.5", 1", $\frac{1}{2}$ "
120 yds: 3"

Restrictions: No dialing allowed. Parallax/Magnification can be adjusted.

Points: 10 points per impact, 100 points possible

Start Position: Standing, rifle and all gear in hand, mag in, action open

Description: On the start signal, build a prone position and engage the targets in the following order:

- $\frac{3}{4}$ - Near
- 1.5 - Far
- $\frac{1}{2}$ - Near
- 1.5 - Far
- $\frac{1}{4}$ - Near

Repeat this sequence starting with the $\frac{3}{4}$ " near target.

Adaptive Recommendation: In position with magazine out and off glass.

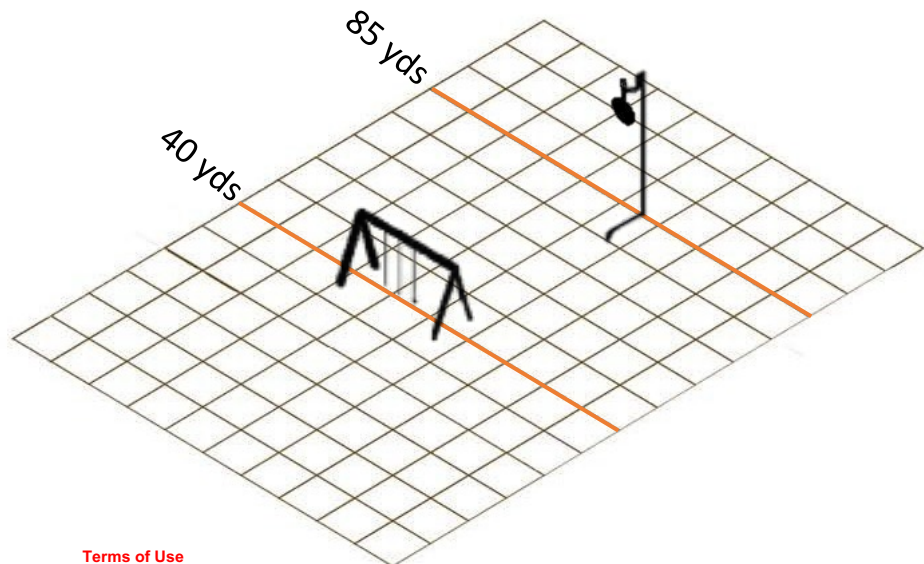

Terms of Use

History Lesson: The Zig Zag Ziguart

Time: 120 Sec

Round Count: 10

Option 1 – 100 yds: 3” on a single hanger

Ranges and Targets:

Option 2 – 150 yds: 6”

Restrictions: None

Points: 10 pts per impact plus 0.1 bonus points per second remaining.

For the PractiScore NRL22 template, enter the total time elapsed in seconds.

Start Position: Standing, rifle and all gear in hand, mag in, action open

Description: On the start signal, engage the target with 1 shot per position starting from the outside lower left and move up one rung after each shot until you reach the highest position you can safely reach.

Then start working your way back down on the outside upper right.

If you can't reach the 5th or 6th position, you'll work your way back up once you reached the outside lower right. i.e. Positions 1, 2, 3, 4, 7, 8, 9, 10, 9, 8.

All engagements are made from the outside most rung.

Adaptive Recommendation: Same starting position. You will start on the highest position you can reach on the left and alternate between the left and right after every shot.

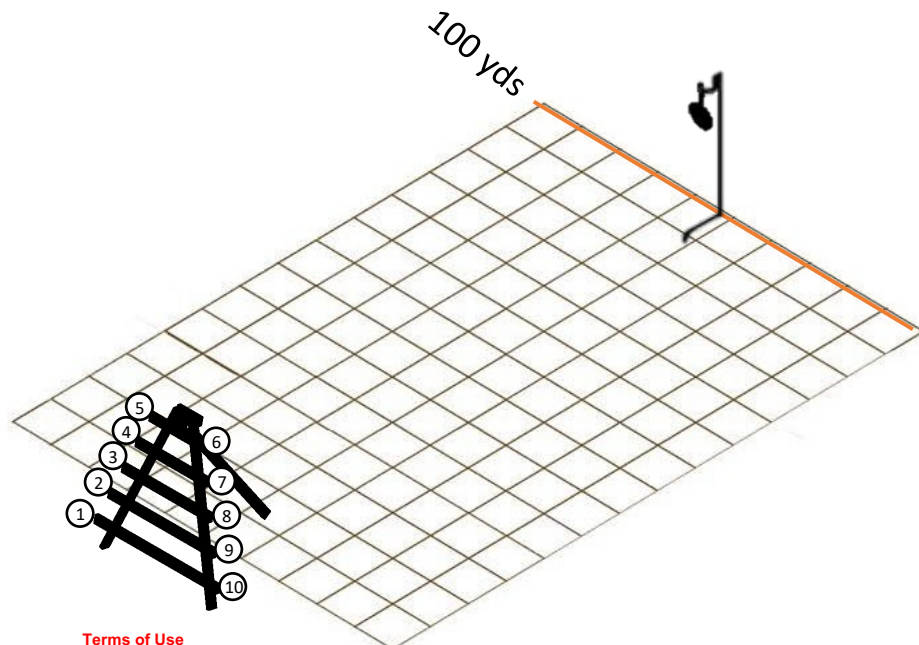

Terms of Use

Angles & Shapes

Time: 120 Sec

Round Count: 10

Option 1 – 70 yds: 2” on a double hanger
70 yds: 2” on a double hanger

Ranges and Targets:

Option 2 – 140 yds: 5”
140 yds: 5”

Restrictions: Bipod may be used but must only touch the prop utilized for that position. E.G. if shooting from the tire position, bipod may not touch the roof.

Points: 10 points per impact, 100 points possible

Start Position: Standing, rifle and all gear in hand, mag in, action open

Description: On the start signal, engage the targets left then right as follows:

- Anywhere on the cinder block(s) – 1 shot each
- Middle of the lower tire - 1 shot each
- Middle of the upper tire - 1 shot each
- Peak of the rooftop (or as high as you can reach) - 2 shots each

Barricade setup: Rooftop positioned sideways. Cinder blocks stacked at bottom of roof top, two on bottom, one on top. Two tires laying on their side on the roof top.

Adaptive Recommendation: Same starting position. 1 cinder block on a 55-gal barrel w/ 1 shot each. 1 shot each from the middle of the upper tire, repeat 1 shot each from the middle of the upper tire, Peak of the rooftop w/ 2 shots each. A stool may be used.

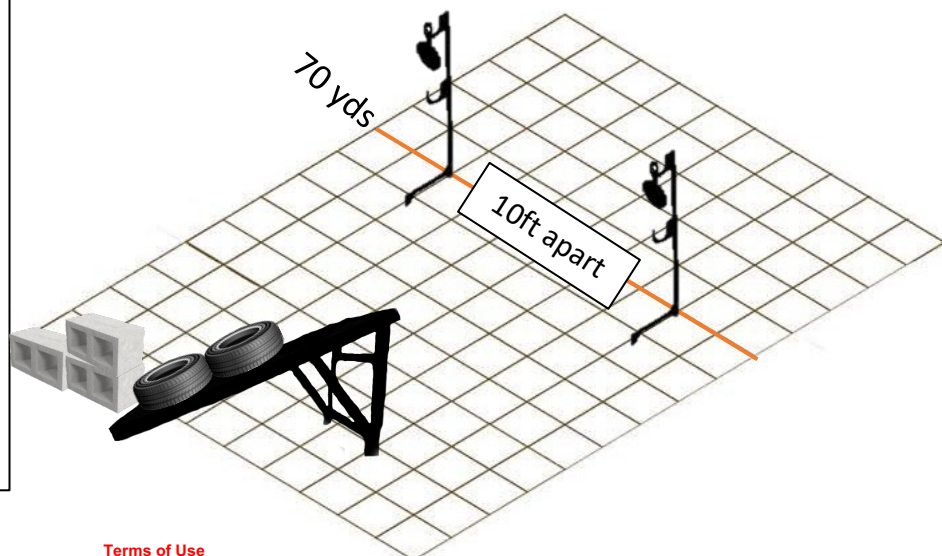

Terms of Use

Don't Lean Back In Your Chair

Time: 120 Sec

Round Count: 12

Ranges and Targets:

Option 1 – 90 yds: 3” on a double hanger

Option 2 – Same targets and distance.

Stressor: 90 sec par time

Restrictions: None

Points: 10 points per impact, 120 points possible

Start Position: Standing, rifle and all gear in hand, mag in, action open

Description: On the start signal, engage the target from the following positions:

- Back of the chair - 5 shots
- Seat of the chair - 4 shots
- Under the chair - 3 shots

You must conduct a magazine change after shot #3 but before the last shot.

If a magazine change is not conducted and all shots were fired then the last 2 shots will not be scored regardless if they were impacts.

Adaptive Recommendation: Same starting position. All shots will be taken from the back of the chair. A stool may be used.

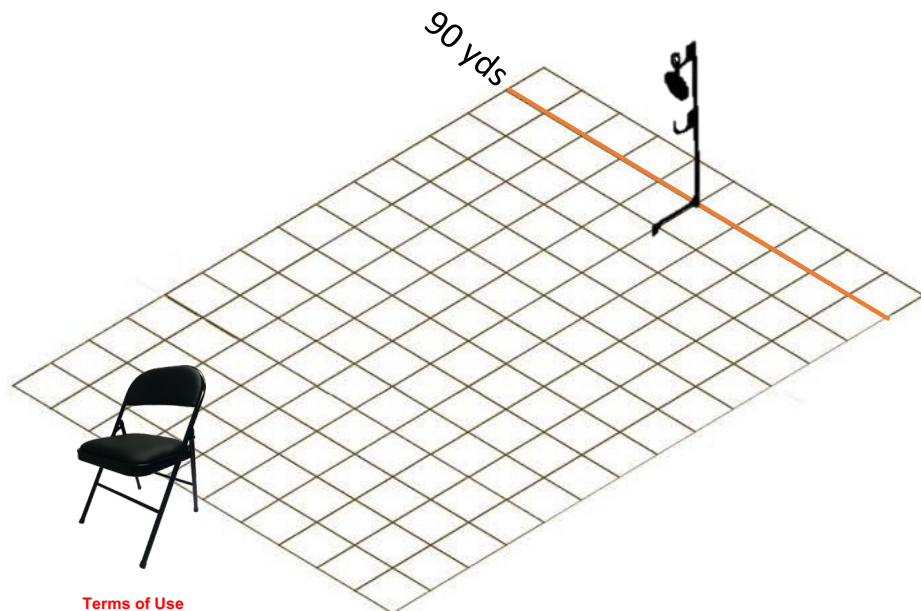

Terms of Use